

RSM-10, RCM-10, RSM20 Remote Monitor Setup and Operation Manual

PR010 Revision 1

This manual covers the setup and operation of the CNA automation remote monitor system.

Optional CineNet and related equipment is covered in the following product reference manuals:

- PR001 CNA Installation Manual
- PR002 CNA-200 Setup and Operation Manual
- PR003 CNA-150 Setup and Operation Manual
- PR004 CNA-100 Setup and Operation Manual
- PR005 QDC-400 Installation and Setup Manual
- PR006 ACP-50 Installation and Setup Manual
- PR007 RVC-5 Installation and Setup Manual
- PR008 PCI-64 Gateway Interface Installation
- PR009 CineNet Host Software
- PR010 RCM-10/RSM-10/RSM-20 Installation and Operation Manual
- PR011 Strong Dimmer Installation, Setup, and Operation Manual
- PR012 eCNA-100 Automation Manual
- PR013 eCNA-150 Automation Manual
- PR014 eCNA-200 Automation Manual
- PR016 Strong FP350 Installation and Operation Manual
- PR017 Eprad FP350 Installation and Operation Manual
- PR018 Paging system Setup and Installation Manual
- PR019 VNC Setup and Operation Manual
- PR020 CineSuite Installation and Operation Manual

Warranty

CineNet automation products, sold by STRONG INTERNATIONAL, are warranted against defects in materials and workmanship for one year from the date of purchase. There are no other express or implied warranties and no warranty of merchantability or fitness for a particular purpose.

During the warranty period, STRONG INTERNATIONAL will repair or, at its option, replace components that prove to be defective, provided the unit is shipped prepaid to the manufacturer directly or via an authorized distributor. Not covered by this warranty are defects caused by modification, misuse or accidents and any further damage caused by inadequate packing for service return.

STRONG INTERNATIONAL's obligation is restricted to the repair or replacement of defective parts and under no circumstances will STRONG INTERNATIONAL be liable for any other damage, either direct or consequential.

Information in this document is subject to change without notice. No part of this document may be reproduced or transmitted in any form or by any means, electronic or mechanical, for any purpose, without the express written permission of STRONG INTERNATIONAL.

© 1997 - 2005 STRONG INTERNATIONAL. All rights reserved.

Table Of Contents:

- Overview** 1
 - Product Description 1
 - Control Panel 2

- Installation** 5
 - Mounting the Remote Monitor 6
 - Wiring the Remote Monitor 7
 - Emergency Stop Input 8

- Configuring the System** 9
 - Remote Monitor setup 10
 - Alarm loudness setting 12

- Final checkout and operation** 12

- Troubleshooting with the Remote Monitor 13

- System Specifications 14

- Troubleshooting 14

- Index 15

Overview

The RSM-10 Remote Status Monitor is a ten-station monitor designed specifically for the theater industry. The RSM-20 is basically two RSM-10's in a convenient package designed for larger multiplexes. These computer-controlled remote monitors are designed to be compatible with all STRONG CNA Automations and allow each projection booth in a cinema multiplex to be monitored from a central location.

This manual provides the installer and user with the necessary information to install, set up and operate the RSM-10/RCM-10/RSM-20[®] remote monitor. The installer is encouraged to read all sections of the manual before proceeding with the installation. If while installing or operating the RSM series monitors you find any part of manual to be unclear or incorrect please let us know. Call STRONG INTERNATIONAL at 402-453-4444 if help or additional information is required.

Product Description

The RSM unit is a microcomputer-controlled remote monitor designed to display the status of all the projection booths in a cinema multiplex. The monitors are wired to the CNA automation system's Local Synchronous Network (LSN) and can be located in various places throughout the building such as the projection booth, manager's office and candy counter to provide the personnel with a real time account of each movie house.

The RSM series monitors feature four LEDs for displaying the status of each projection booth. Indicated are 'ready to run', projector running, timed or clock start mode, fault and intermission. Each unit is equipped with a sonic alarm and an alarm cancel switch.

The remote monitors are connected to the CNA automations via the 2-wire synchronous data bus in a *daisy-chain* configuration. This eliminates the laborious wiring required by the conventional remote stations often needing hundreds of wires and terminations.

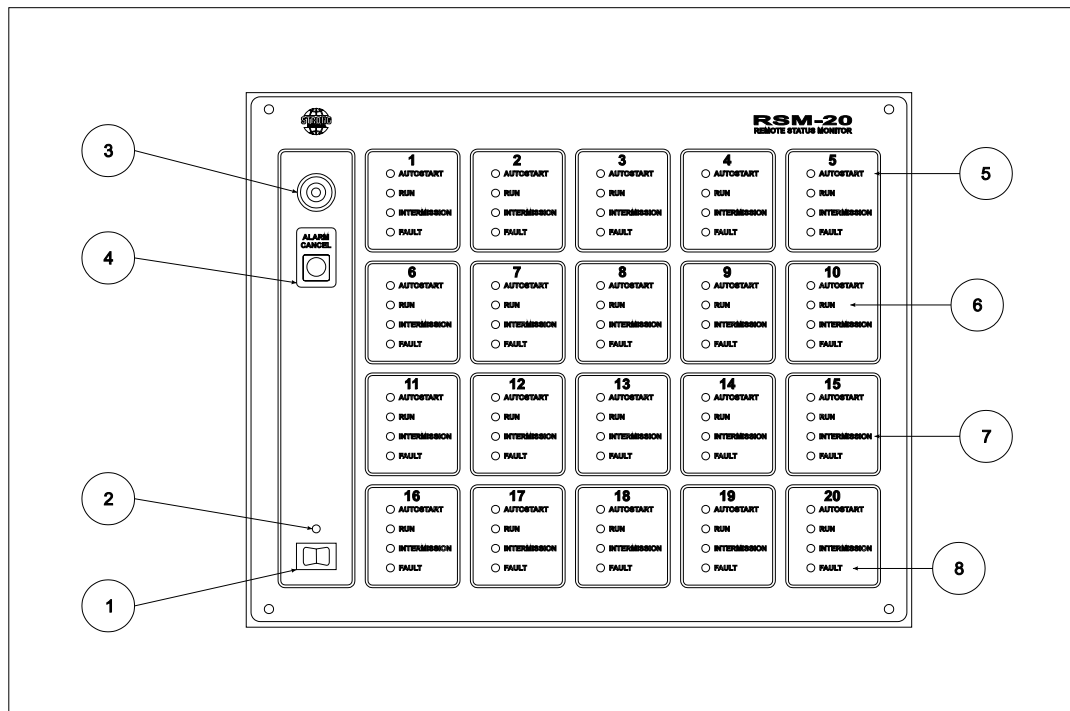

Figure A: RSM-20 Control Panel

Control Panel

The front panel layout incorporates twenty separate control/status stations. Each contains four LEDs to display show status. An alarm is provided to indicate a fault condition and an alarm cancel switch to silence the alarm at the remote station. The RSM-10 of course only features 10 status displays for monitoring 10 CNA automations.

1) Power Switch

Used to turn on the remote monitor.

2) Power LED

The red power LED is on when power (120 vac/60Hz or 240 vac/50Hz) is applied to the unit.

3) Alarm

The Alarm is sounded to indicate a fault at a CNA automation. The Alarm is sounded at all remote monitors on the Sync Loop. The alarm can be cancelled at any one of the remotes (on the Sync Loop) or at the CNA that initiated the alarm. The alarm loudness can be set for one of three intensities; LOW(87 dBA), MEDIUM (94 dBA) or HIGH (98 dBA) or can be disabled if desired. See *Configuring the System* section.

4) **Alarm Cancel**

This switch is used to silence the alarm in the event of a fault. The Alarm Cancel switch will silence the remote monitor alarm and *all* other remote monitor alarms on the Sync Loop. Alarm Cancel will also cancel the alarm at the CNA Automation.

The ALARM CANCEL switch can also be used for a self-test. Press this switch for seven (7) seconds to enter the self-test mode. The remote monitor will begin to cycle through the LEDs lighting two at a time starting with station number 1 and station 11. This testing will continue until the switch is pushed again or a five (5) minute timer expires. Pressing the CNA START switch will force the AUTOSTART and RUN LEDs on.

5) **Autostart LED (yellow)**

on	show is <i>ready to run</i> and is in <i>timed</i> or <i>clock start</i> mode.
off	show is <i>in progress</i> or in <i>manual start</i> mode.

6) **Run LED (green)**

on	projector motor is running.
blinking	show is <i>ready to run</i> or <i>ready to resume</i> .
off	show is stopped.

7) **Intermission LED (yellow)**

on	between shows.
blinking	show is stopped not due to a fault. (This includes a programmed intermission.)
off	projector motor is running or show is stopped due to a fault.

8) **Fault LED (red)**

on	show is stopped due to a fault and alarm has been cancelled or show is not running and failsafe does not detect the presence of film.
blinking	show is stopped due to a fault and alarm is sounding.
off	fault does not exist.

Note: The RCM-10 features a keypad overlay with individual start and stop buttons for each automation. This allows the user to perform a “remote start/stop” of their automation if enabled. See Illustration #'s 9 and 10 below.

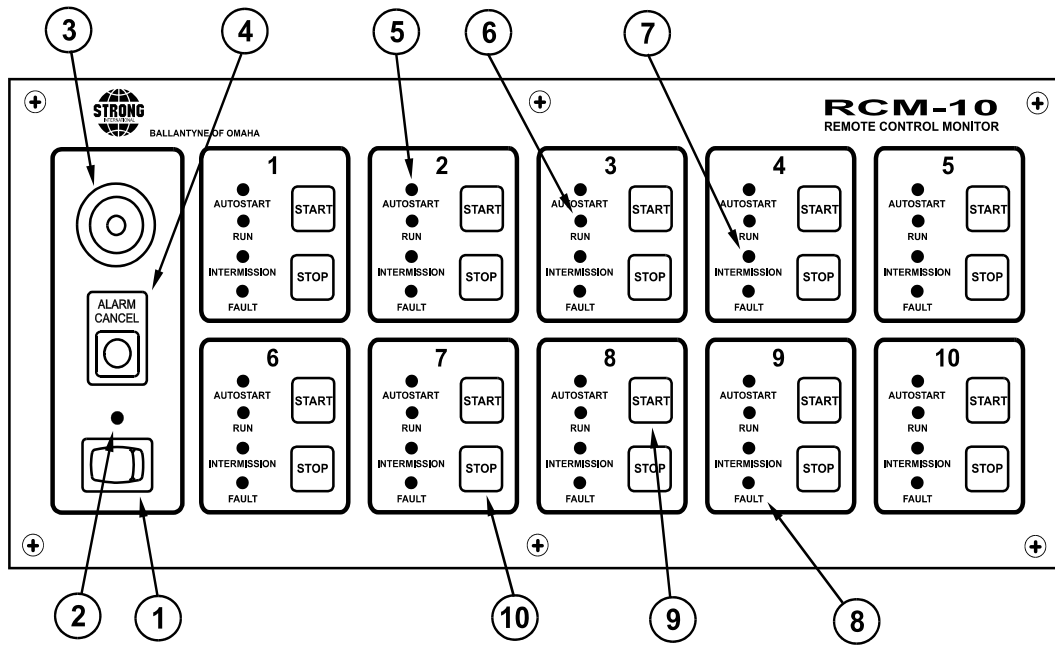

Figure B: The RCM-10

The table below summarizes the eight status conditions displayed by the remote station.

		READY TO RUN IN AUTOSTART MODE	READY TO RUN IN MANUAL START MODE	SHOW RUNNING	READY TO RUN DURING A PROGRAMMED INTERMISSION	READY TO RESUME	BETWEEN SHOWS & FAILSAFE FAULT	SHOW STOPPED DUE TO A FAULT & ALARM IS SOUNDING	SHOW STOPPED DUE TO A FAULT & ALARM HAS BEEN CANCELLED
AUTOSTART	ON	OFF	OFF	OFF	OFF	OFF	OFF	OFF	OFF
RUN	BLINK	BLINK	ON	BLINK	BLINK	OFF	OFF	OFF	OFF
INTERMISSION	ON	ON	OFF	BLINK	OFF	ON	OFF	OFF	OFF
FAULT	OFF	OFF	OFF	OFF	OFF	ON	BLINK	ON	ON

Figure c: Status Table

Installation

The equipment should be carefully inspected for signs of visible damage resulting from transportation and handling. Please notify the freight carrier immediately if damage is found.

First, verify that Each power supply inside the unit is set to the same voltage (120 or 240) that is powering the unit. If it is not, move the jumpers labeled W1 and W2 to the appropriate locations. The RSM-10 has only one power selector whereas the RSM-20 has two to set. It is important that the installer configure both properly on the RSM-20.

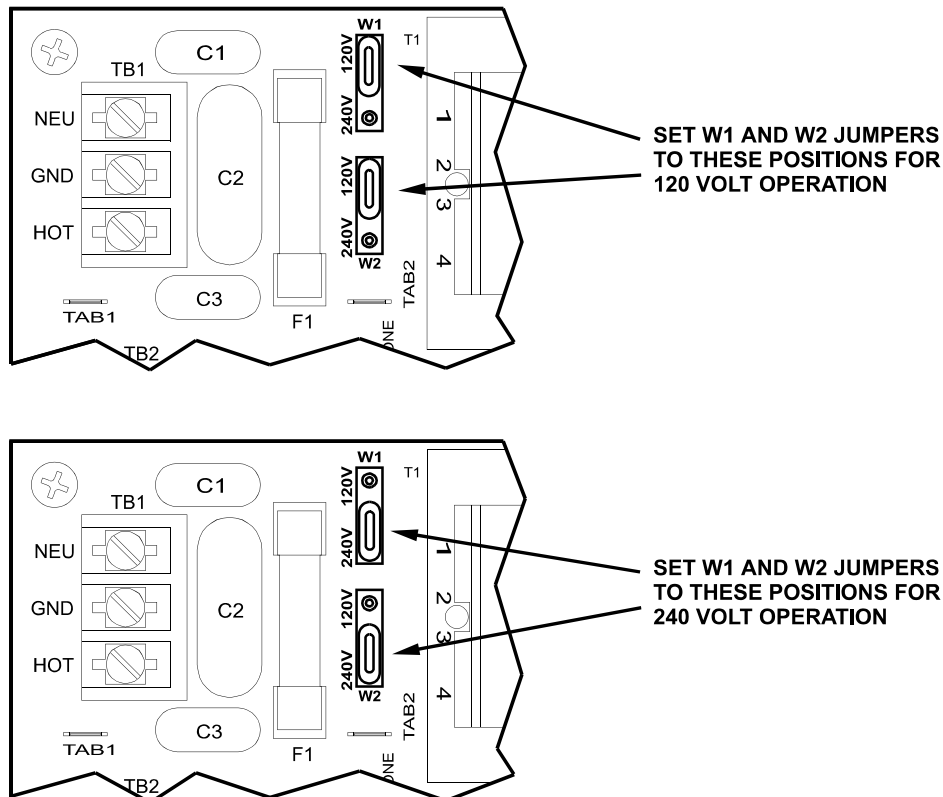

Figure D: Power supply Voltage Selector

Mounting the Remote Monitor

The four (4) mounting holes are keyholes capable of accepting #10-24 screws with a maximum head diameter of 3/8 inches. The cabinet is designed to be surface or flush mounted, 1/8 inch diameter holes in each end of cabinet are provided for wall stud mounting. Next, prepare the cabinet for mounting by removing the desired knockouts. Several 7/8 inch knockouts are provided in the cabinet for external wiring of power and communications. *Note:* optional hardware is available for rack mounting the monitor and an optional trim ring is available for both units for flush mounting. This gives a cleaner more professional looking installation

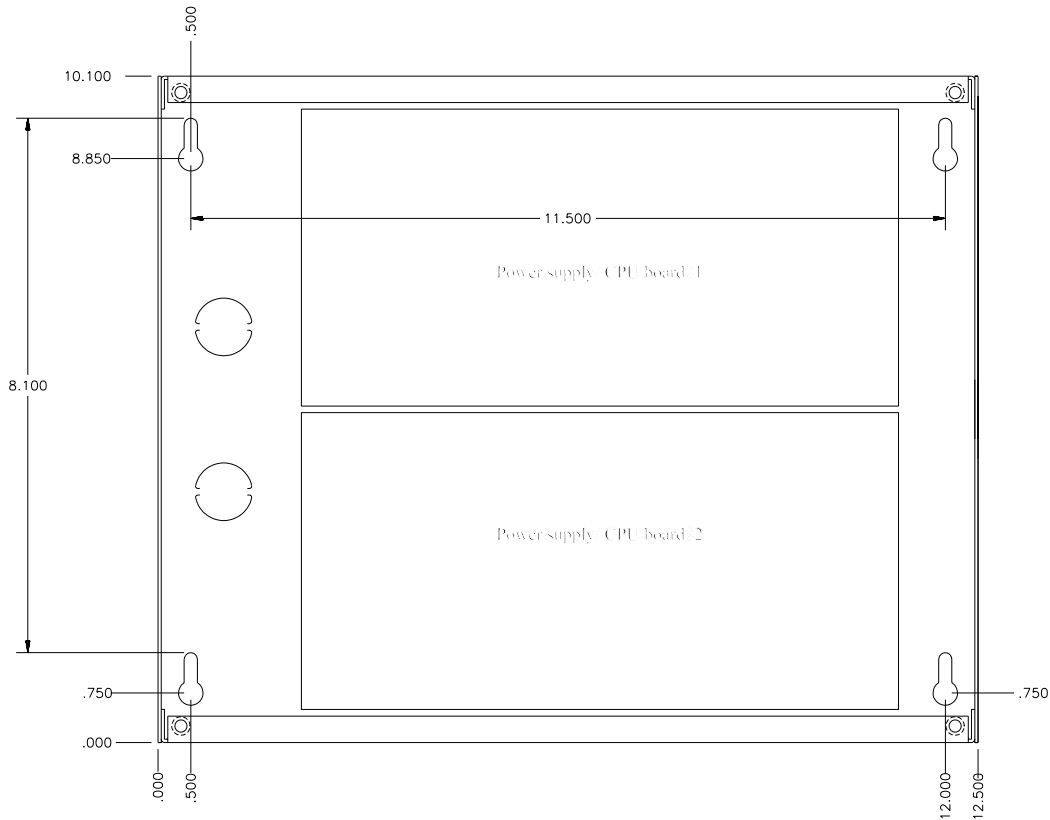

Figure E: Remote Monitor Cabinet

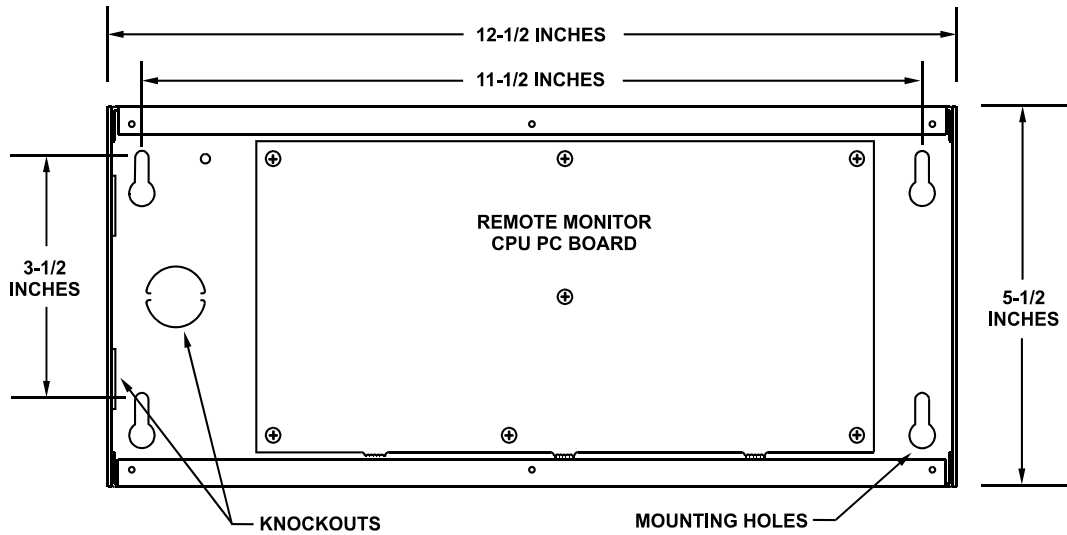

Figure F: The RSM/RCM-10 Remote Monitor Cabinet

Wiring the Remote Monitor

Remember that during installation insure that all requirements of the National Electric Code and local codes are satisfied. For remote units installed in the projection booth, be sure to run *clean* power (dedicated to the Remote Monitors and CNA systems only) to all Remote Monitors and CNA automation systems from the service entrance panel or closest branch panel. The line, neutral and ground wires should all run back to the main service panel (separate from all other loads). It is acceptable and preferred if all remotes and automations were run from a single distribution point.

Important Note: Do not connect the projector motors, changeovers, xenon rectifiers or other heavy or noisy loads to this circuit.

TB1 is the AC power input termination. This terminal block is located in the upper left corner of the pc board. The monitor will operate on 120 or 240 vac. **MAKE CERTAIN** the jumpers on the power supply are set to the correct voltage before applying power. Since the RSM-20 is basically 2 RSM-10's in a single enclosure, power can be wired to either unit's terminal block. They are wired in parallel with each other.

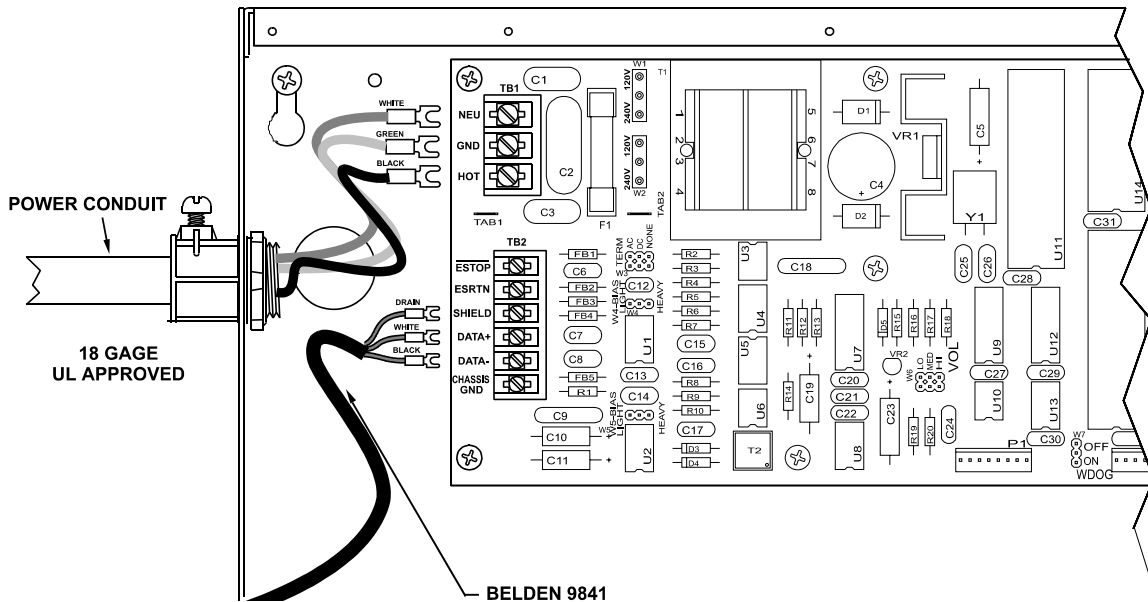

Figure G: Power and Communications termination

Communication wiring between the CNA automations and Remote Monitors is accomplished using 2-conductor, twisted pair with a shield. Wire gage is dependent on the length of the wire needed. In general, 22 gage is sufficient. Many cable manufacturers offer a broad range of 120-ohm cables designed for RS-485 applications. We recommend **Belden 9841** or equivalent. Also be certain *polarity* is observed. The LSN communications wiring is also in parallel so it is not important which terminals get LSN connection.

See *figure G*.

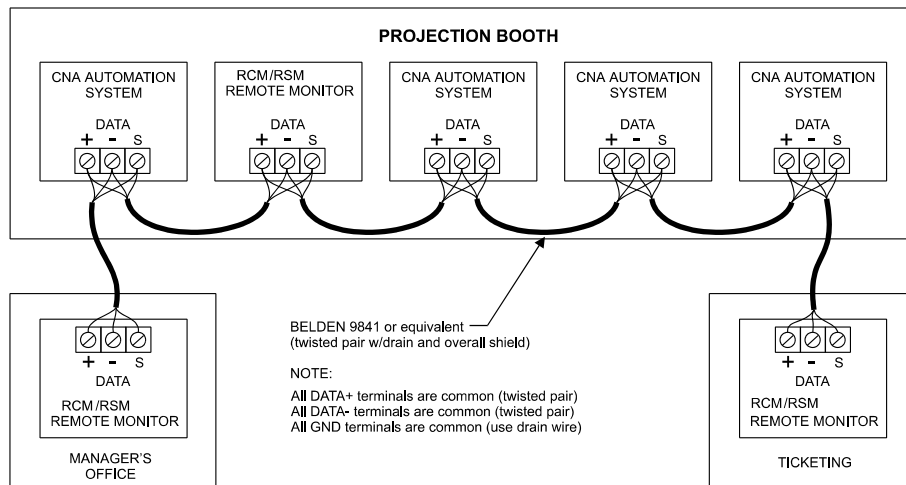

Figure H: Daisy Chain topology

When planning the communication wiring, keep the cable away from equipment that generates electrical noise, such as power conduits, fluorescent lighting fixtures, air conditioners, etc. Choose cable routing paths in such a way to prevent damage to the cable.

The required method for communication wiring of the Remote Monitor/CNA automation system is the *daisy-chain* configuration, a system in which the transmission line continues from one unit to the next. See figure F for the *daisy-chain* connection topology. Do not branch or spoke devices.

Emergency Stop Input

Each Remote Monitor features a master *Emergency Stop* input. This is designed to be wired to the Fire Alarm System. Shorting the two inputs labeled ESTOP and ESRTN (TB2-1 and TB2-2) at any Remote Monitor will force a stop condition to all CNA systems on the network. The connection should be made to a normally open *dry* relay contact as shown in *figure I*.

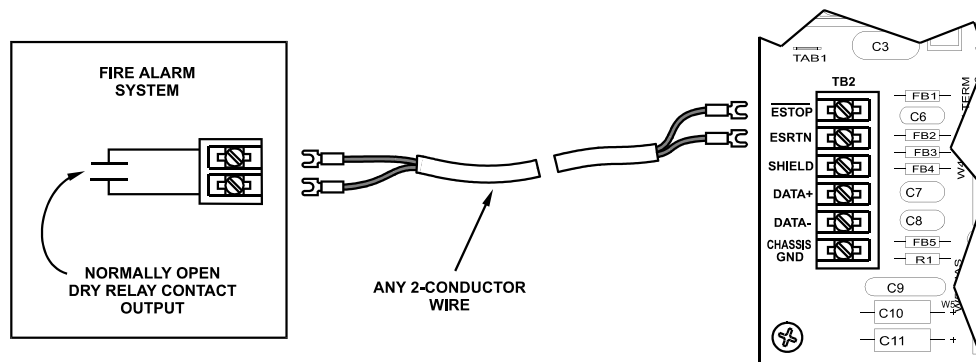
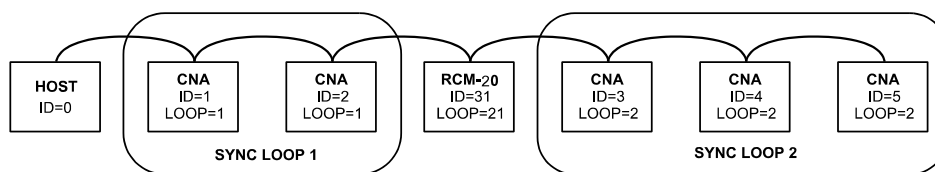

Figure I: Emergency Stop wiring

Configuring the System

The synchronous communications *network* can support up to 64 devices (Remote Monitors, CNA automations and a Host). **Remote Monitors and CNAs will each require a unique ID number.** In the case of the RSM-20 each individual mainboard will require a different ID. ID 0 will be used by the *Host PC*, IDs 33 to 63 are assigned to Remote Monitors as necessary and IDs 1 to 63 are assigned to CNAs as necessary. Normally the CNA's ID numbers will be assigned starting at 1. The Remote Monitor's IDs should be assigned to the higher numbers starting at 63 and working down. Note that as many Remote Monitors can be assigned to a sync loop number as desired (switches and LEDs all will work in parallel). *Figure J* below demonstrates the Sync Loops and IDs within a network.



NOTE:

The CNAs assigned to SYNC LOOP 1 can be run in interlock when desired.
The CNAs assigned to SYNC LOOP 2 can be run in interlock when desired.

Figure J: Sync Loop and ID numbers

Within the Sync network, a maximum of 20 *sync loops* can be defined. The CNA uses sync loops to run projection systems in *interlock*. The legal range of CNA sync loop numbers are 1 through 20. For large multiplexes that want to monitor more than twenty CNAs on the network, up to six Remote Monitors can be **grouped** together to monitor up to fifty-seven (57) houses with one group of three Remote Monitors. The maximum number of devices that can be connected to the Sync network at one time is 64 and one is the *Host PC*. Remember, with larger installations, each RSM-20 Shows up on the network as TWO remote monitors. For very large multiplexes it may be practical to divide the network into two smaller networks. Call the factory for suggestions on planning the wiring in a large multiplex.

Sync loop numbers 21 through 26 are predefined and used for Remote Monitors.

Remote Monitor setup

First locate the eight position DIP switch designated SW1. See *figure K* .

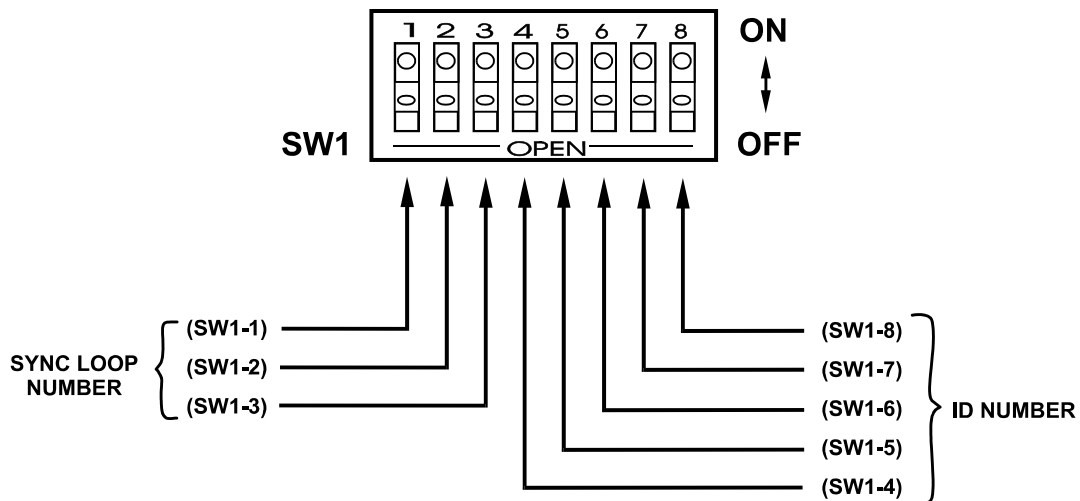

Figure K: DIP Switch

To configure the Remote Monitors for Loop number the DIP switches SW1-1 through SW1-3 must be set as follows:

Remote Monitor CNA's at ID	Sync Loop Number	Remote Monitor DIP switch setting		
		SW1-1	SW1-2	SW1-3
1 to 10	21	OFF	OFF	OFF
11 to 20	22	OFF	OFF	ON
21 to 30	23	OFF	ON	OFF
31 to 40	24	OFF	ON	ON
41 to 50	25	ON	OFF	OFF
51 to 60	26	ON	OFF	ON

To configure the Remote Monitors for ID number the DIP switches SW-4 through SW-8 must be set as follows for each Monitor Board:

LSN ID Number	Remote Monitor DIP switch setting				
	SW1-4	SW1-5	SW1-6	SW1-7	SW1-8
63	ON	ON	ON	ON	ON
62	ON	ON	ON	ON	OFF
61	ON	ON	ON	OFF	ON
60	ON	ON	ON	OFF	OFF
59	ON	ON	OFF	ON	ON
58	ON	ON	OFF	ON	OFF
57	ON	ON	OFF	OFF	ON
56	ON	ON	OFF	OFF	OFF
55	ON	OFF	ON	ON	ON
54	ON	OFF	ON	ON	OFF
53	ON	OFF	ON	OFF	ON
52	ON	OFF	ON	OFF	OFF
51	ON	OFF	OFF	ON	ON
50	ON	OFF	OFF	ON	OFF
49	ON	OFF	OFF	OFF	ON
48	ON	OFF	OFF	OFF	OFF
47	OFF	ON	ON	ON	ON
46	OFF	ON	ON	ON	OFF
45	OFF	ON	ON	OFF	ON
44	OFF	ON	ON	OFF	OFF
43	OFF	ON	OFF	ON	ON
42	OFF	ON	OFF	ON	OFF
41	OFF	ON	OFF	OFF	ON
40	OFF	ON	OFF	OFF	OFF
39	OFF	OFF	ON	ON	ON
38	OFF	OFF	ON	ON	OFF
37	OFF	OFF	ON	OFF	ON
36	OFF	OFF	ON	OFF	OFF
35	OFF	OFF	OFF	ON	ON
34	OFF	OFF	OFF	ON	OFF
33	OFF	OFF	OFF	OFF	ON

Alarm loudness setting

The alarm loudness can be set for one of three intensities; LOW(87 dBA), MEDIUM (94 dBA) or HIGH (98 dBA) or can be disabled if desired.

See *figure J* below.

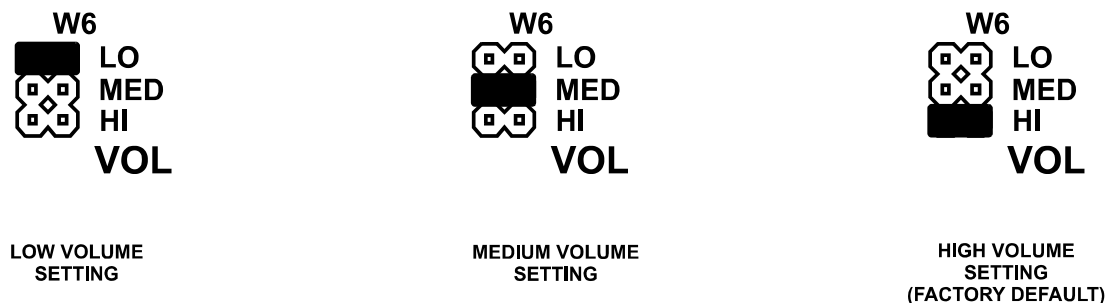

Figure J: Alarm Volume

Final checkout and operation

When the electrical installation is completed and the all CNA automations and Remote Monitors are correctly configured, power up all devices on the network. Follow the steps outlined below to verify proper operation.

1. Check the Local Sync Network Status screen on each CNA to determine that all CNA-200s and Remote Monitor IDs are displayed.
2. Check each Remote Monitor. The power LED should be lit. At least one of the LEDs should be lit on each active station. If the film is not loaded at the CNA the INTERMISSION LED should be on. Refer to the *Control Panel* section for a description of the status LEDs.
3. Take each CNA through a *dummy* run and verify the status LEDs on all Remote Monitors.

Troubleshooting with the Remote Monitor

The red LED labeled LED 1 on each mainboard is a communications status indicator. The LEDs will either be blinking at a *fast rate* (on 3 times per second), a *slow rate* (on 1 time per second) or *off*. This status LED can provide much information and will aid in troubleshooting the Remote Monitor and the network.

The following table shows the three modes of LED status and the conditions that may exist. This table assumes you have attempted to wire the network.

<p>(1) Fast Blinking Rate - Monitor OK. Communications OK.</p> <p>1. The Remote Monitor is working and is communicating properly with CNAs, Gateway, or other LSN Device.</p>
<p>(2) Slow Blinking Rate - Monitor OK, but not communicating with LSN Devices.</p> <p>1. Data (+) and Data (-) are open. 2. Data (+) and Data (-) are shorted together. 3. CNAs connected to the network are not powered up. 4. The ID number is set the same somewhere else on the network.</p>
<p>(3) Off - Monitor maybe OK. Communications not OK.</p> <p>1. Only Data (+) is open. 2. Only Data (-) is open. 3. Data (+) is shorted to shield. 4. Data (-) is shorted to shield. 5. Data (-), Data (+) or shield are cross wired. 6. ID number is set to zero (0). 7. The Remote Monitor is not working.</p>

If there are no LEDs lit on the front panel (except for the power LED), the possible causes are:

1. The Sync Loop number is not set correctly.
2. CNAs connected to the network are not on.
3. Data (+) and/or Data (-) are open.
4. Data (+) and Data (-) are shorted together.
5. Data (+) and/or Data (-) are shorted to shield.
6. Data (-), Data (+) or shield are cross wired.
7. The Remote Monitor is not working.
8. ID number is set to zero (0).

System Specifications

General:

Power requirements	8.5 watts (maximum)
Input Voltage	90-130 VAC or 180-260 VAC (user selectable) 50-60 Hz single phase
Input Power Fuse	1/2 amps 3AG normal blow
Dimensions	Width 12-1/2 in. (31.8 cm) Height 10 in. (25.5 cm) Height RSM-10 5 in (12cm) Depth 3 in. (7.6 cm)

Communication:

Format	RS485
Configuration	Half duplex
Protocol	SCIBEK (Bit-oriented protocol developed by <i>TL Industries</i> for the theatre industry)

Troubleshooting

PROBLEM: A Remote Monitor is missing from the Network Overview screen on the Host or the LSN status on a CNA-200.

CHECKS: Is the power LED *on* at the Remote Monitor?

Are any other LEDs on the front panel working?

Remove the control panel and check the DIP switch configuration at the Remote Monitor to be sure **sync ID** and **sync loop** numbers are correct (Refer to *Configuring the System* section).

Be sure the STATUS LED on the pc boards are blinking.

If the Remote Monitor is at the end of a transmission line are the "DATA +" and "DATA -" wires reversed or not connected?

Index:

Alarm	2
Alarm Cancel	3
Alarm loudness setting	12
Autostart LED	3
Cable routing paths	8
Checks	14
Clean power	7
Communication: Format	14
Configuration	14
Daisy-chain	8
Description	1
Dimensions	14
DIP switch	10
Eight status conditions	4
Emergency Stop input	8
ESTOP	8
ESRTN	8
Fault LED	3
Final checkout	12
Front panel layout	2
Fuse	14
ID.	9
Input Voltage	14
Installation	5
Intermission LED	3
Loop number	10
Mounting the Remote Monitor	6
Overview	1
Power LED	2
Power requirements	14
Power Switch	2
Protocol	14
Remote Monitor setup	10
Run LED	3
Specifications	14
Troubleshooting	13
W1 and W2	5
Wiring the Remote Monitor	7

List of Illustrations:

Figure A	Control Panel (RSM-20)
Figure B	Control Panel (RCM-10)
Figure C	LED status table
Figure D	Power supply voltage selection
Figure E	Cabinet dimensions and mounting (RSM-20)
Figure F	Cabinet dimensions and mounting (RxM-10)
Figure G	Power and Communications wiring
Figure H	Daisy chain topology
Figure I	Emergency Stop wiring
Figure J	Sync loop and ID
Figure K	Dip switch settings
Figure L	Alarm volume configuration

RxM Major replacement parts:

Below is a listing of the major components that make up the RxM-x0, use this table when ordering replacements or inquiring about repairs.

Part Description	Strong P/N	OEM P/N
Power supply/CPU board, mounts inside cabinet (Specify Type)		35970
Display Board, mounts to front (Specify Type)		35970
Alarm		35982
Power Switch		62884
Front Panel Overlay (RCM Keypad)		35975