

# STRONG International FP-350

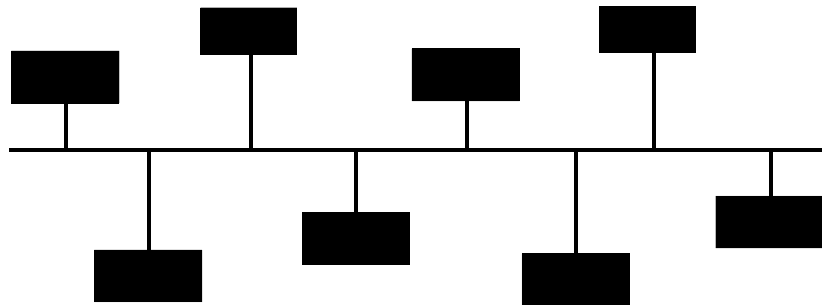

---

## Operation and Installation Manual

---



Revision 2.00  
June 2005



# *FP-350*

OPTICAL FAILSAFE  
&  
PROXIMITY CUE DETECTOR

# **STRONG FP-350**

## **Installation, Setup and Operation Manual**

### **PR016 Revision 2**

---

This manual covers the setup and operation of the FP-350 Optical Failsafe/ Cue detector.

Optional CineNet and related equipment is covered in the following product reference manuals:

- PR001 CNA Installation Manual
- PR002 CNA-200 Setup and Operation Manual
- PR003 CNA-150 Setup and Operation Manual
- PR004 CNA-100 Setup and Operation Manual
- PR005 QDC-400 Installation and Setup Manual
- PR006 ACP-50 Installation and Setup Manual
- PR007 RVC-5 Installation and Setup Manual
- PR008 PCI-64 Gateway Interface Installation
- PR009 CineNet Host Software
- PR010 RCM-10/RSM-10/RSM-20 Installation and Operation Manual
- PR011 Strong Dimmer Installation, Setup, and Operation Manual
- PR012 eCNA-100 Automation Manual
- PR013 eCNA-150 Automation Manual
- PR014 eCNA-200 Automation Manual
- PR016 Strong FP350 Installation and Operation Manual
- PR017 Eprad FP350 Installation and Operation Manual
- PR018 Paging system Setup and Installation Manual
- PR019 VNC Setup and Operation Manual
- PR020 CineSuite Installation and Operation Manual

---

### **Warranty**

CineNet automation products, sold by STRONG INTERNATIONAL, are warranted against defects in materials and workmanship for one year from the date of purchase. There are no other express or implied warranties and no warranty of merchantability or fitness for a particular purpose.

During the warranty period, STRONG INTERNATIONAL will repair or, at its option, replace components that prove to be defective, provided the unit is shipped prepaid to the manufacturer directly or via an authorized distributor. Not covered by this warranty are defects caused by modification, misuse or accidents and any further damage caused by inadequate packing for service return.

STRONG INTERNATIONAL's obligation is restricted to the repair or replacement of defective parts and under no circumstances will STRONG INTERNATIONAL be liable for any other damage, either direct or consequential.

---

Information in this document is subject to change without notice. No part of this document may be reproduced or transmitted in any form or by any means, electronic or mechanical, for any purpose, without the express written permission of STRONG INTERNATIONAL.

© 1997 - 2005 STRONG INTERNATIONAL. All rights reserved.

**Table of Contents:**

Product Description ..... 1

Setting Up the Cue Detector Board ..... 2

Wiring the FP-350 ..... 4

Installation ..... 5

Setting Bobble Delay ..... 6

Cue Placement ..... 7

General Maintenance ..... 7

Theory of Operation ..... 8

Troubleshooting ..... 10

Replacement Parts ..... 11

## **Product Description**

The Strong model FP-350 optical failsafe and proximity cue detector is a solid-state cue detector and failsafe. This design eliminates clumsy failsafe arms as well as the routine maintenance tasks commonly associated with conventional units such as cleaning dirty cue detector rollers.

The cues are sensed by proximity detectors positioned at the outside edges of the film. The proximity detectors sense the aluminum cue foil. When one or both of the proximity detectors sense a cue, the circuitry determines whether the cue sensed is an inboard, outboard, or cross cue. The circuitry then closes the appropriate relay contacts. Units with one proximity detector will only sense an inboard or an outboard cue determined by the setup of the cue detector board. These units do not have the ability to sense a cross cue.

Faults are sensed using a pair of infrared emitter-detectors located just inside the sprocket holes on each side of the film. Using a pair of film detectors allows the unit to detect film splits as well as film breaks. The emitter sends a beam of light which the film reflects back to the detector. The circuitry determines whether film is present and closes a set of relay contacts. The FP-350 also incorporates a variable bobble delay. This gives the unit an adjustable amount of time between the detection of a fault and the output reporting a fault condition.

## Setting Up the Cue Detector Board

For units with only one proximity detector, it may be necessary to set the cue detector board depending on whether inboard or outboard cues are to be used. First check the underside of the FP-350 and compare it to figure 1 to determine whether the unit is set to detect the desired cues. If it is necessary to rotate the cue detector board, disassemble the failsafe as shown in figure 2a-2d. For ease of access, disassembly is best performed prior to installation. Unplug the cue detector board, rotate it for the desired cues and reinsert it into the same plug. Reassemble the unit in the reverse order.

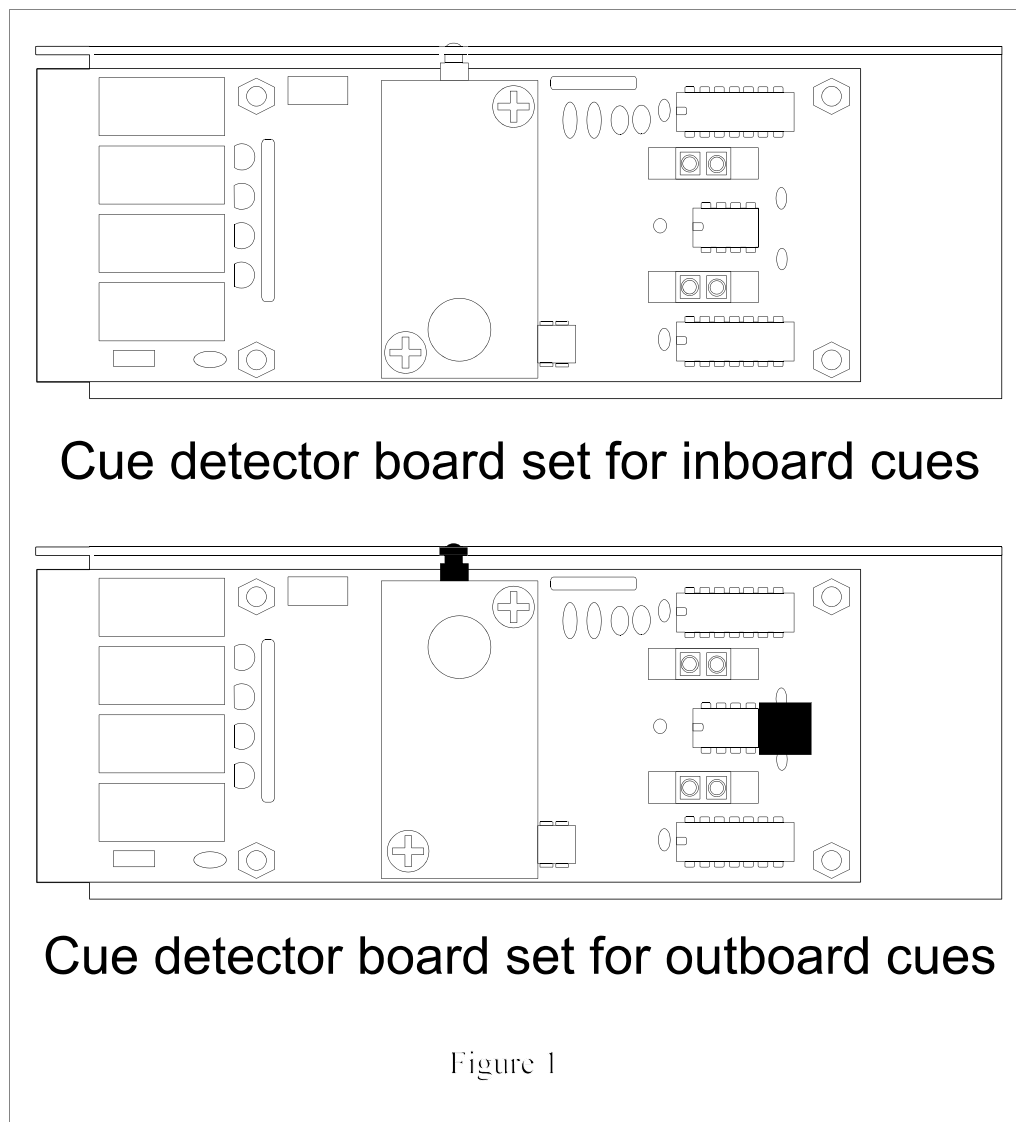
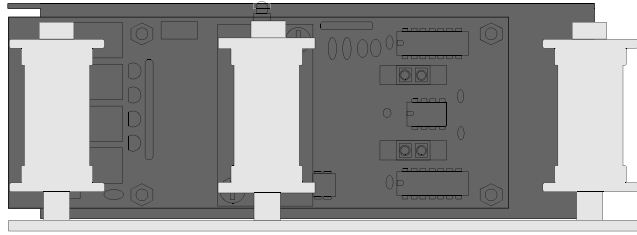

Figure 1



Bottom of cue detector / failsafe  
Figure 2a

Remove these two screws to gain access to failsafe PCB

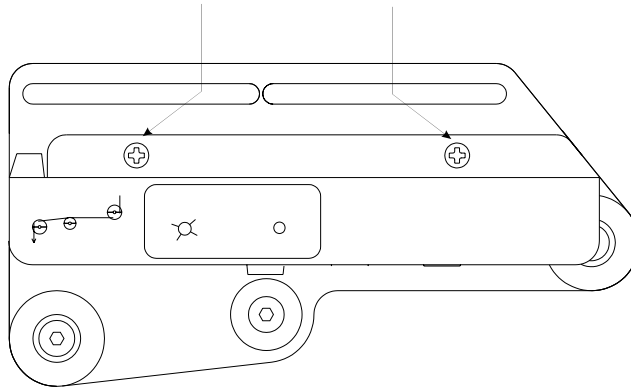
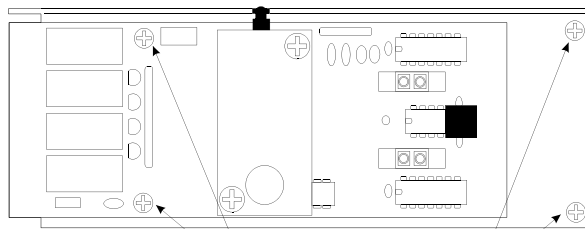
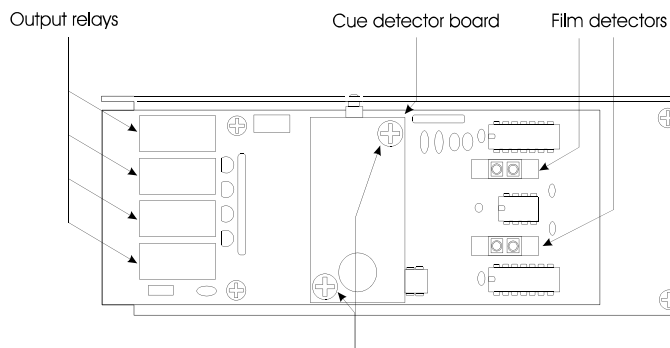

Figure 2b



To gain access to cue detectors, remove these four screws  
Figure 2c



To gain remove cue detector board, remove these two screws

Figure 2d

## Wiring the FP-350

The FP-350 requires a 12VDC supply of at least 150mA. This may be supplied by the automation, such as the EPRAD ultimation 2000, or it may be supplied by a plug-in wall module. Wiring is easier if performed prior to installation. Connect the 12VDC from the power supply to the terminal marked +12VDC on the FP-350 and connect the power supply ground to the terminal marked Gnd. The FP-350 is protected against damage by reverse wiring of the +12 volt supply. The outputs are dry relay contacts with a current rating of 2A @28 VDC.

Connect the appropriate open or closed failsafe terminals to the automation(refer to the automation manual).

All three cue outputs are common to the terminal marked common. This should be connected to the automation's supply or ground as required by the automation. The inboard, outboard, and cross cues are wired to the automation as described in the automation manual.

To eliminate possible wiring problems, the relay output terminals are isolated from the power supply. The failsafe relay and the cue detector relays are also isolated from each other.

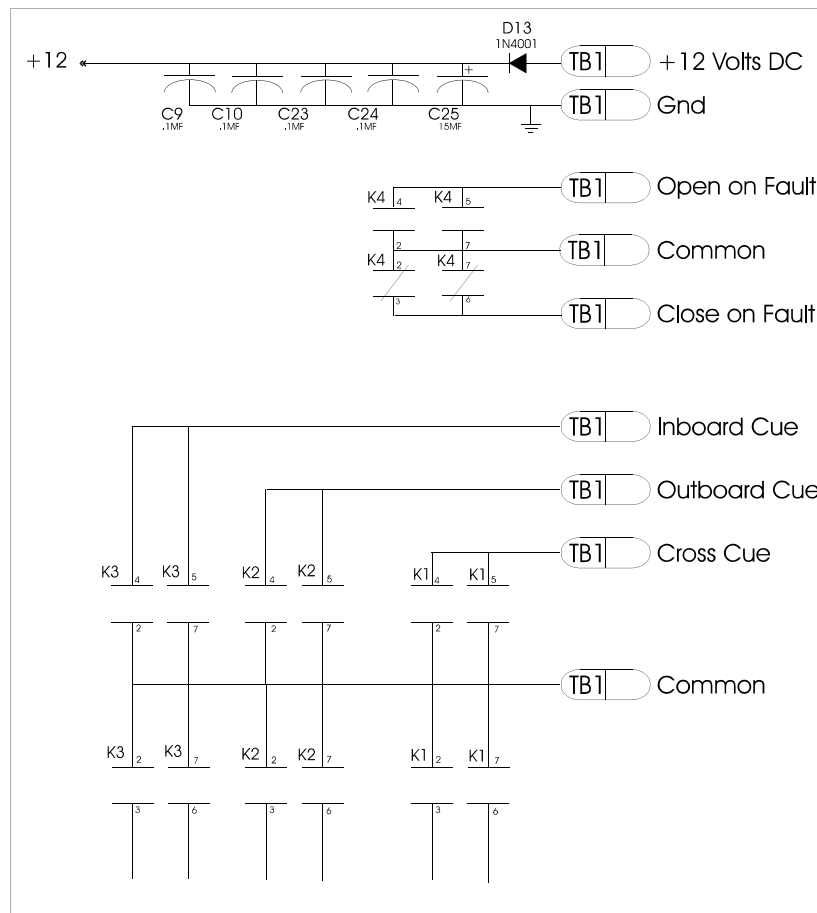



## Installation

Install the FP-350 as shown in figure 3. The mounting bracket is bolted to the soundhead through the two slots. When mounting the FP-350, make sure the film comes from the projector and enters and exits the rollers straight. This can be adjusted by sliding the mounting bracket in and out on the soundhead.

The roller bracket and assembly is attached to the mounting bracket through two slotted holes to enable the unit to be moved forward and backward under the soundhead. If necessary, loosen these two screws and adjust the roller bracket so the film the failsafe nearly vertical.

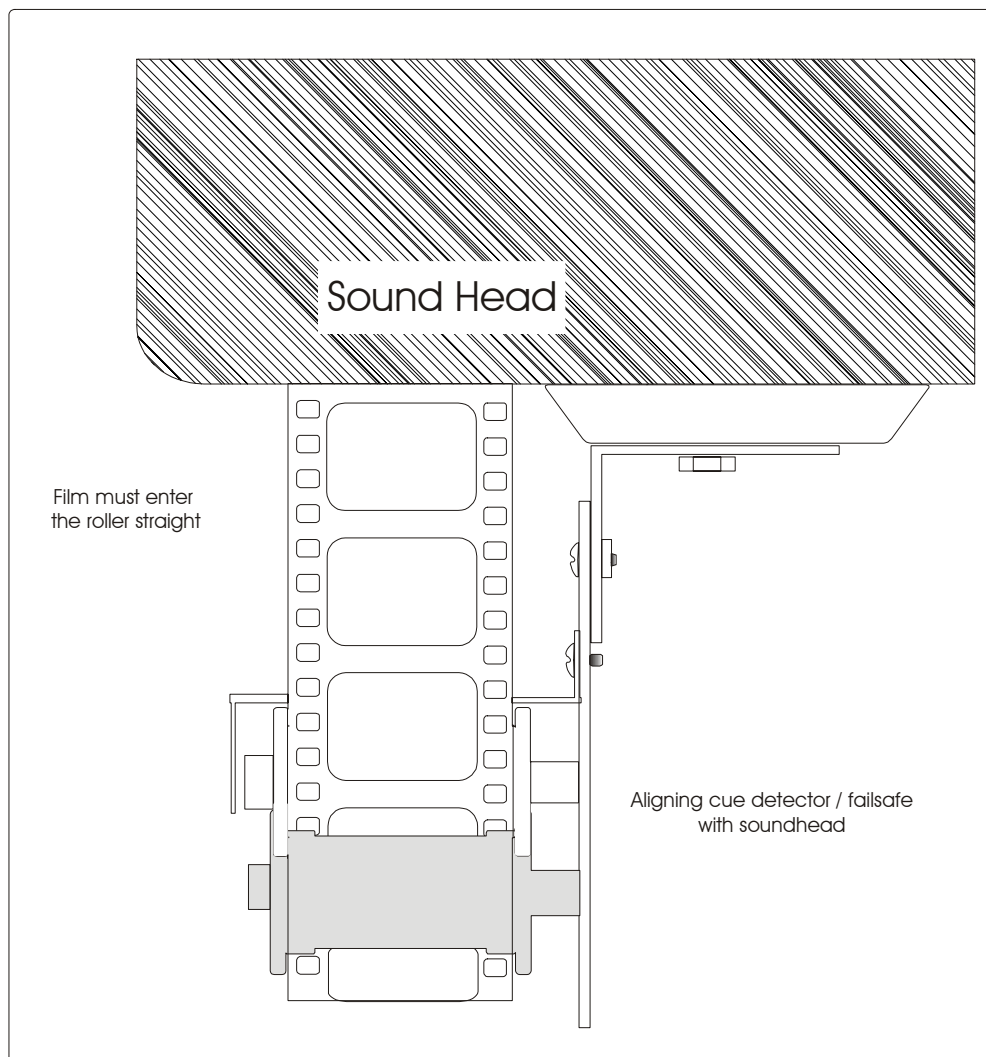

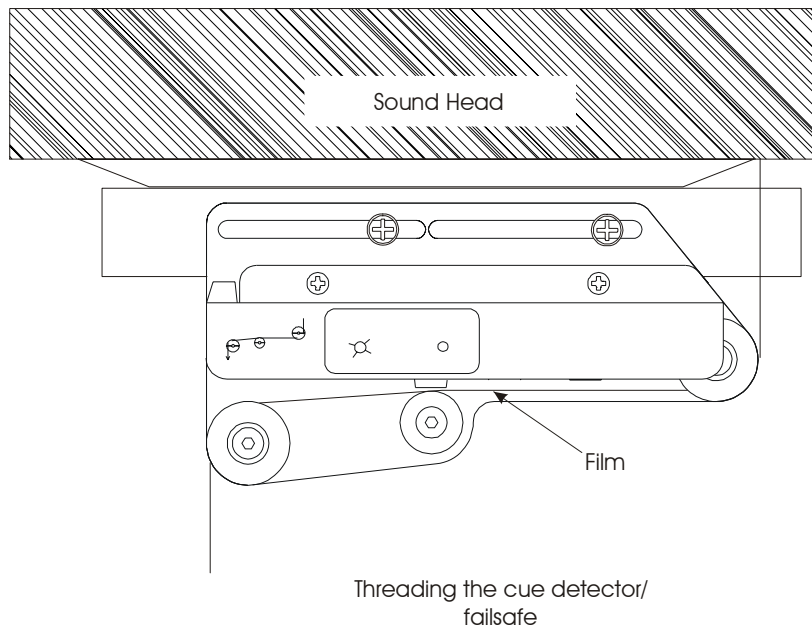
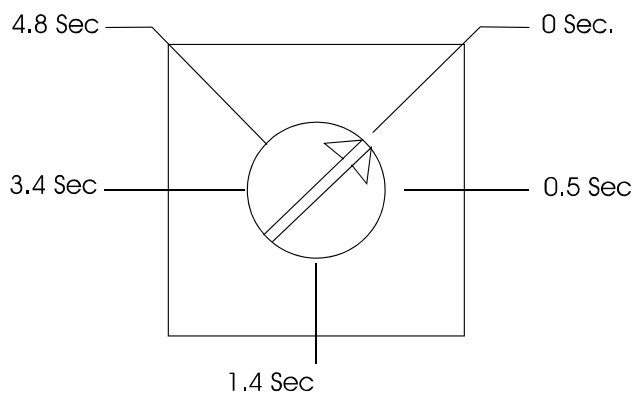

Figure 4

### Setting Bobble Delay

The bobble delay will eliminate faults caused by film sag during startup. The range of delay is adjustable from 0 to 5 Seconds. For most installations a delay of 1 Second is sufficient.

Use a small screw driver to turn the bobble delay pot until desired delay is achieved. The delay time can be checked by putting a piece of paper, film, etc about 4 mm from both film sensors at the same time. After the fault LED turns off, pull the object away. The time it takes for the fault LED to light is the bobble delay time.



Bobble delay Time

## Cue Placement

With the FP-350 proximity cue detector, there are some requirements for the placement of cues on the film. For all cues placed on the film, the recommended minimum cue foil length is 1/2 Inch. The recommended maximum cue length 2 inches, although longer cue foil can be used if required.

When placing cue foil on the film, it is not necessary to wrap the foil around the edge of the film. The proximity detectors don't require electrical conduction, they detect the presence of the aluminum. because of this, old or cracked cues are reliably detected.

Because of the special requirements of cross cues, the inboard and outboard cues must be at least 2 inches from each other. If the two cue foils are too close together, a cross cue may result.

To place a cross cue on the film, place an inboard and outboard cue on the film in the same place. The beginning and ends of each cross cue foils must be within 1 inch of each other. When the circuitry determines that both inboard and outboard cues are present, the cross cue relay will close while the inboard and outboard relays remain open.

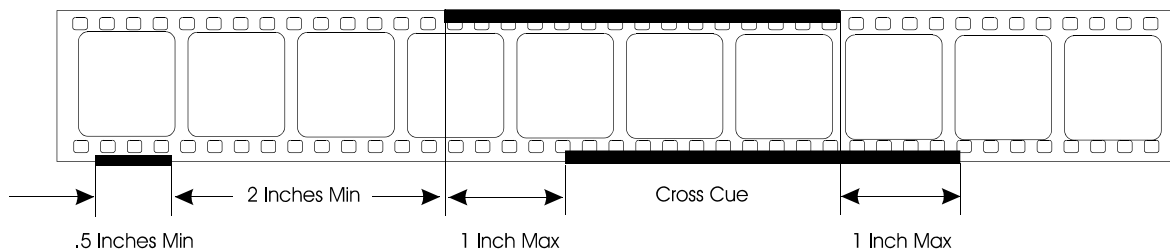

## General Maintenance

Because the film sensors are light sensing devices, it is important that the emitter and detectors are kept clean.

Be certain to keep the circuit board clear of water or oil. Water and oil may conduct electricity and cause the board to malfunction. If the circuit board should become dirty or oily, wash with water and soap if required. Rinse the board thoroughly and let dry completely before applying power.

## Theory of Operation

The FP-350 consists of two separate circuits, the optical failsafe and the cue detector circuit.

The optical failsafe circuit starts with an oscillator which feeds the two optical sensor LEDs. The light pulses are reflected back to the detectors. The detectors produce a current which is proportional to the amount of light received. The signal is amplified by a current to voltage converter, then fed into a high pass filter to remove unwanted dc component from the signal created by ambient light. The high pass filter also removes any low frequency components from florescent lighting, noise etc... The remaining high frequency signal is amplified again to a useable level. The signal is then rectified to convert the AC signal into a DC level. The lowest of the two DC levels from the detectors is compared against a reference, if the signal is greater than the reference, a high is produced at the bobble delay. This charges a capacitor which is compared against the bobble delay voltage reference. If a fault is detected the detector will produce a low. This low allows a capacitor at the bobble delay to discharge. When the voltage on the capacitor becomes less than the DC voltage set by the bobble delay potentiometer, the output relay will indicate a fault. The lower the DC voltage is set on the bobble pot, the longer it will take for the relay to indicate a fault.

The cue detector circuit starts at the proximity detectors. The proximity detectors appear as a near short circuit when metal is not present. When metal comes within close proximity to the detector, it acts like an open which forces the output of the detector high. This signal charges a capacitor very quickly through a diode. The diode creates a pulse stretcher by slowing the rate of discharge. The output of the pulse stretcher is compared against a reference DC level. If the output of the pulse stretcher is higher than the reference voltage, a high logic level is produced at the output. The logic levels produced from both detector circuits provide the input to AND logic. The AND gate determines whether the cue detected was an inboard outboard or cross cue. Each Different type of cue triggers an output from its appropriately labeled relay contact outputs. The combined stretched input pulse and the delayed output provide a cue pulse equal in duration but delayed approximately 0.1 Sec.

Optical Failsafe

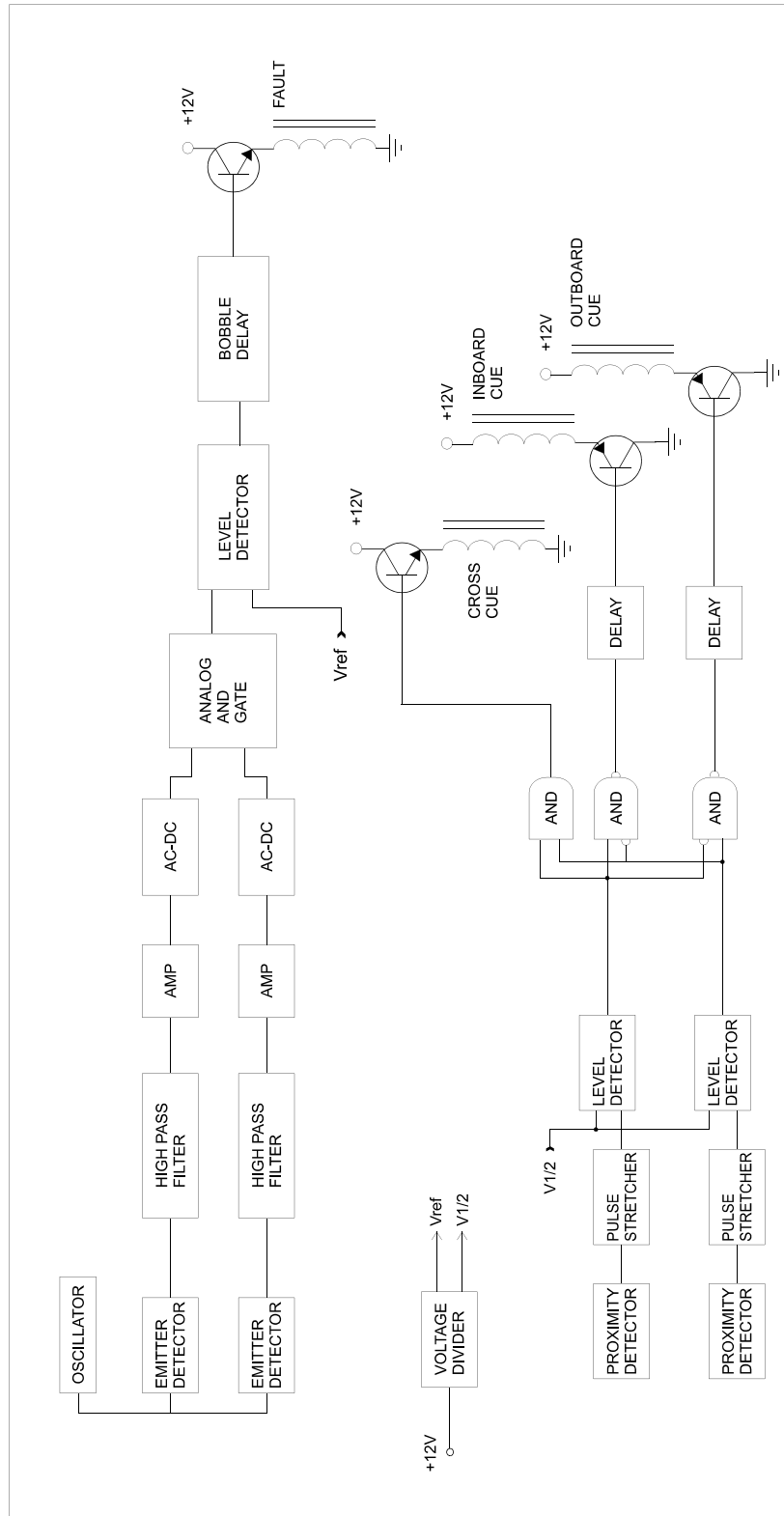

Proximity Cue Detector

## TROUBLESHOOTING

- |  |
|--|
| <ol style="list-style-type: none"><li>1. Make sure that the unit is receiving power.<ol style="list-style-type: none"><li>a. The automation must be turned on if it is supplying power to the FP-350</li><li>b. Check the fault LED. When no film is present, it should be lit. If the fault light is off and the failsafe relay indicates a fault, then the problem is most likely in the power supply wiring. The FP-350 will indicate a fault if the unit loses power.</li><li>c. A loss of power would also be the cause of cue detectors not sensing foil. The cue detector can be tested by placing any metal object close to the detector and listening for a relay closure. The sense distance for the detectors is about 2 mm for the cue foil.</li><li>d. A lack of power could be caused by connecting the power supply backward. The circuit board has protection which will prevent damage if the wiring is reversed.</li></ol></li></ol> |
| <ol style="list-style-type: none"><li>2. If the FP-350 is receiving power, then the sensors must be tested.<ol style="list-style-type: none"><li>a. To test the film sensors, put a piece of paper, film, etc... approximately 4mm from both sensors at the same time. When both sensors detect an object in front of them, the fault LED will turn off.</li><li>b. To test the proximity detectors, place a metal object close to the detector and listen for a relay closure.</li></ol>** If any test in section 2 failed, then the result is likely to be internally damaged and will require repair.</li></ol>   |
| <ol style="list-style-type: none"><li>3. If the circuit board checks out OK, then the next possible cause is the wiring to the automation.<ol style="list-style-type: none"><li>a. Check the wiring at both the automation and the FP-350.</li><li>b. Check for loose wires and criss-crossed wires.</li><li>c. The wiring can also be checked by shorting the appropriate terminals on the terminal block to ensure conduction.</li></ol></li></ol>   |

**REPLACEMENT PARTS**

PART#	PART DESCRIPTION
37701	Mounting bracket
37702	Roller plate
37703	PCB mounting bracket
37704-1	PCB assembly
37705-a	Cover plate A
37705b	Cover plate B
37706	Film guide rollers
37707	Film trap roller
63290	1/4" x 1.5" shoulder bolt 10-24

1. Strong will only accept orders from authorized dealers.
2. All prices are subject to change without notice
3. Minimum order charge is 35.00 per shipment per destination.
4. All shipments are FOB Omaha NE
5. Any materials being returned for any reason must be sent post paid.
6. Strong will not accept incoming material not identified with a RAN (return authorization number)